

Determining the Cause of AFCI Tripping Branch/Feeder and Combination Arc Fault Circuit Interrupters Class 760

Precautions

⚠ DANGER

HAZARD OF ELECTRIC SHOCK, EXPLOSION OR ARC FLASH

This document is written for qualified electricians. Other than connecting and disconnecting receptacle loads, the work described here should be done only by trained professionals.

Failure to follow these instructions will result in death or serious injury.

Introduction

When an AFCI trips, the cause of the trip must be determined before placing the circuit back into service. This data bulletin outlines several of the most common causes of AFCI tripping however it does not cover all possible causes that can occur.

Arc Fault Circuit Interrupters (AFCIs) are required for installation in residences under the 2002 National Electrical Code® (NEC®). The 2005 NEC requires AFCIs to transition from the present (branch/feeder) AFCIs to combination AFCIs.

The QO® and Homeline® Combination Arc-fault Circuit Interrupters, also referred to as CAFCI, were developed to meet the NEC 2005 requirements effective January 1, 2008.

Types of AFCIs

Arc Fault Circuit Interrupters (AFCIs) are devices intended to mitigate the effects of arcing faults by functioning to de-energize the circuit when an arc-fault is detected. It is important to understand which device you have before attempting to determine the cause of AFCI tripping.

Branch/Feeder AFCI: An arc fault circuit interrupter intended to provide protection for branch circuit wiring against unwanted effects of arcing. Square D branch/feeder AFCIs have either blue or green test buttons.

Combination AFCI: An arc fault circuit interrupter provides the same protection as the branch/feeder AFCI with the additional protection for branch circuit extension wiring (including power cords, extension cords, etc.). Square D combination AFCIs have white test buttons.

Figure 1: Types of AFCIs (Example Labels)

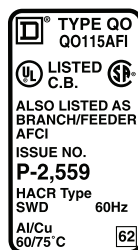

Branch/Feeder AFCI
(Blue or Green Test Button)

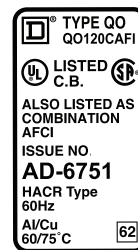

Combination AFCI
(White Test Button)

Causes of AFCI Tripping

A standard QO or Homeline circuit breaker will trip to protect a circuit from overloads or short circuits. In addition to standard circuit breaker protection, AFCIs mitigate against the effects of arc faults.

If an AFCI trips soon after it has been installed, the cause of the tripping may be different than if the AFCI has been in service for some time. The cause of tripping for newly installed AFCIs is much more likely to be incorrect installation, and much less likely to be an appliance problem.

An AFCI can trip by one of the following causes:

- Overloads (Page 2)
- Short circuits (Page 2)
- Improper AFCI Installation (Page 3)
- Ground faults (Page 5)
- Damaged AFCI (Page 5)
- Arc faults (Page 6)

Some specific examples of several of these causes are described on pages 8 and 9.

AFCI Trip due to Overload

An overload trip is caused by a circuit carrying more current than the handle rating of the circuit breaker allows. For example, a 20 A circuit breaker can carry a load totaling 2,400 watts (at 120 V), but should not be loaded with more than 80% or 16 A (1,920 watts) continuous, per the NEC.

The overload feature of most circuit breakers (including AFCIs) works via a bi-metal component of the circuit breaker heating and bending to cause the circuit breaker to open. Its operation is a function of the time and current. Tripping occurs after a delay; the greater the overload, the faster the circuit breaker will trip.

NOTE: When calculating loads, always include everything on the circuit. Keep in mind that the circuit may serve loads outside the affected room.

First check to see if there are high current loads overloading the circuit. Be sure to check all receptacles on the circuit, not only the receptacles in the affected room. Calculate the loads to ensure they don't exceed the circuit breaker's carrying capacity.

An example of an overload trip is described on page 8

AFCI Trip due to Short Circuit

A short circuit allows a very high amount of current to flow through the circuit. A short can be between either line to the neutral or line to ground.

As with most circuit breakers, an AFCI has an electromagnetic function that opens almost instantaneously when it detects a short circuit, typically in less than one-tenth of a second. It is important that the circuit breaker operates quickly to avoid damage to the conductors between the load center and the short circuit.

Short Circuits

If a circuit breaker trips instantaneously when an appliance is plugged in or turned on, remove the appliance from the circuit and turn the circuit breaker on. If the circuit breaker does not trip, there is possibly a short circuit in the appliance or its electrical cord.

If there does not appear to be a short circuit in one of the plugged-in devices, including the electrical cords, then there may be a short circuit in the permanent wiring. Before checking the circuit, remove all power from the circuit by moving the AFCI handle to the OFF position. Next, unplug all the devices from all receptacles on the circuit and turn off all lights or other loads. Finally, using an ohmmeter at the load center, check the resistance between line and neutral and line and ground. If either measurement shows low resistance (less than one kilohm), there is a short circuit between those conductors (or there are still connected loads). High resistance indicates the likely absence of a short circuit. For additional information, refer to "Types of Faults Leading to AFCI Tripping" on page 7.

High Inrush Currents

One phenomenon that appears as a short circuit to a circuit breaker (including AFCIs) is high inrush current. Consider receptacles with one-half switched by a light switch. High inrush current can occur when several loads (or one large load) are connected to the switched half of the receptacles.

If all of the individual loads (plugged into the switched half of the receptacle) are in the ON position, and then the light switch that controls these receptacles is then switched ON, a momentary high inrush current that far exceeds the normal operating current of these loads may occur. This will appear as a short circuit to a circuit breaker and cause it to trip. The solution to this situation is to simply plug most of the loads into the non-switched half of the receptacles. This will avoid turning on several of the loads simultaneously.

Improper AFCI Installation

NOTE: The AFCI includes a test button on the front. Its purpose is to verify that the AFCI is functioning properly. This test button only functions if the AFCI is installed correctly.

Inadvertent Grounded Neutral

A special type of ground fault (but a frequent one) is an inadvertent grounded neutral. This occurs when the neutral conductor contacts a grounded conductor (ground wire, grounded outlet box, etc.).

This can happen in a receptacle box, switch box, or a fixture. When this condition occurs, the balance between the line and neutral currents no longer exists and the AFCI trips.

Figure 2: Detection of Grounded Neutral

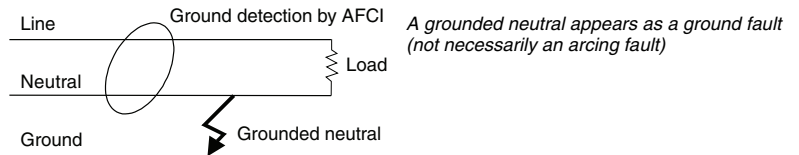

Improper AFCI Connections

The next thing to check is the installation of the AFCI in the load center. Were the connections to the AFCI made properly? It is mandatory that these three connections are correct:

- Load power wire (black)
- Load neutral wire (white)
- Panel neutral wire (coiled, white pigtail)

Make sure the load power and load neutral wires are not intermixed between two or more branch circuits. If they are, the AFCI will immediately trip when any load is applied.

If you see a red wire connected to the load power terminal of the AFCI, see “AFCI Tripping on Circuits with Shared Neutrals” on page 4.

NOTE: Usually, the color-coded wires make it easy to confirm that they were installed in the load center correctly. Refer to the installation instructions that came with the AFCI:

- Branch/feeder AFCIs (blue or green test button):
(bulletin no. 48840-122-xx or 48840-123-xx).
- Combination AFCIs (white test button):
(bulletin no. 48840-248-xx or 48840-249-xx).

Figure 3: Example of Proper AFCI Wiring

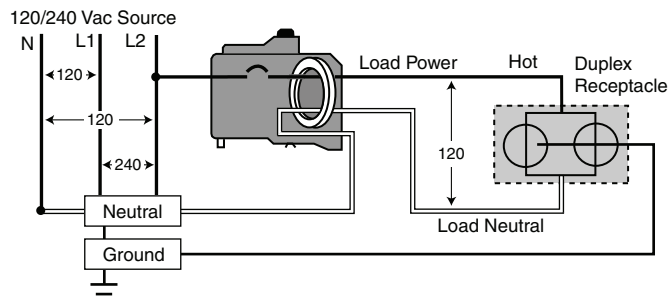

AFCI Tripping on Circuits with Shared Neutrals

A single-pole AFCI will not operate properly on shared neutral wiring. This may not become apparent until a load is applied to at least one of the circuits.

Figure 4: Example of Shared Neutral

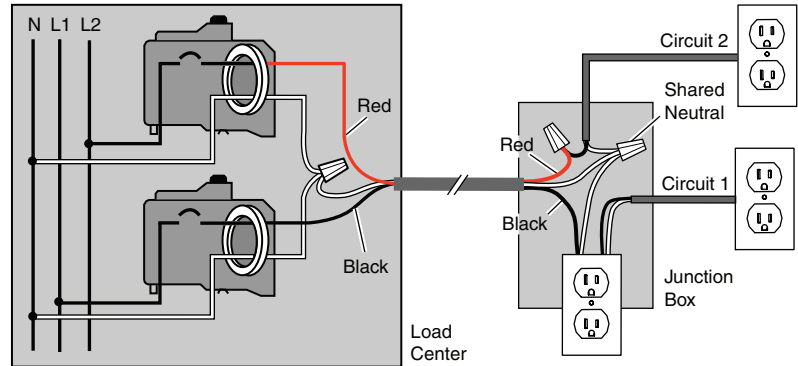

Some localities allow the use of a shared neutral when running a home run cable to two adjacent bedrooms at the far end of a house. Other situations where shared neutrals may be found include:

- separate circuits for lighting and receptacle outlets
- kitchen circuits where under-cabinet outlets are separate from above-counter receptacles

The most obvious clue that there is shared neutral wiring is the presence of a black, a red, and a white wire (in the load center) from one cable going to two single-pole AFCIs (See Figure 4).

The best solution to this is to avoid the use of shared neutrals and their inherent problems.

Serious Disadvantages to Sharing Neutrals

The practice of shared neutrals may seem attractive due to possible savings associated with the reduction of a neutral conductor. However, there are serious disadvantages to sharing neutrals:

- If the shared neutral is lost, the connected loads are subject to voltages varying from 0 to 240 V (line-to-line). This is especially true if one load has much larger impedance than the other. The likely result from this is severe damage to some connected devices due to extreme under- and over-voltage conditions. See Figure 5.
- On two-pole common-trip circuit breakers, both circuits are interrupted during any type of fault. If a shared neutral circuit feeds two rooms, then both rooms lose power if a fault occurs in either. If a shared neutral circuit feeds receptacles and lights, both will lose power with a fault on either one.
- On two-pole independent-trip circuit breakers, one may find hot wires in a junction box that was presumed dead. One cannot overemphasize how dangerous this would be. If one of the shared neutral circuits were to trip due to a short-circuit or overload, the other circuit would remain hot. Anyone servicing any device in that junction box may be exposed to live conductors.

Figure 5: Damaging Voltage Rise Due to Loss of Shared Neutral

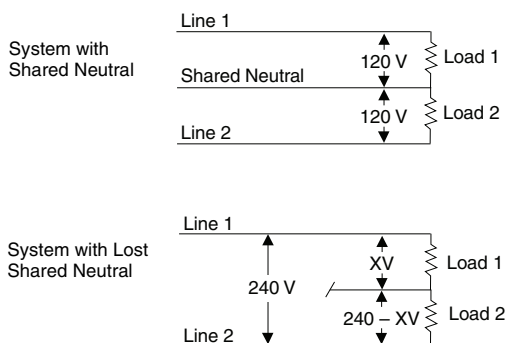

AFCI Trip due to Ground Fault

Ground faults are sometimes called “residual-current” faults or “earth-leakage” faults. They are due to unwanted paths from line to ground or neutral to ground. Unlike a short circuit, ground faults are typically much lower current. Most frequently, ground faults are caused by gradual deterioration of the wiring insulation or by moisture in the circuit.

Figure 6: Diagram of a Ground Fault

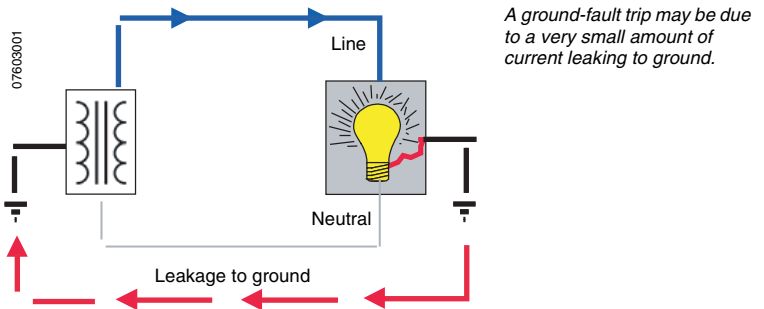

Ground Fault Interrupters (GFIs)

Ground Fault Interrupters (GFIs) can be found in a kitchen, bathroom, utility room, or outdoors. GFIs have the sensitivity (4–6 mA) needed to provide protection for people who might contact the circuit in some way. Square D AFCIs do not provide people protection, but do detect residual current levels starting at approximately 50 mA.

In simple terms, both GFIs and AFCIs detect residual current by comparing the current flowing out on a line with current returning via the neutral. If these currents are not equal, then it is likely that there is an alternate return path, and thus a ground fault.

Locating a Ground Fault

A ground fault can be in either the permanent wiring, in an appliance, or in the appliance cord. If, after all appliances are removed from the circuit, the AFCI continues to trip, there may be a ground fault in the permanent wiring.

A test to check for a ground fault is to temporarily substitute a GFI circuit breaker for the AFCI. The GFI will trip at 4–6 mA which is a lower level than the AFCI. If a ground fault is diagnosed, the faulty circuit (or the appliance) must be replaced or repaired.

NOTE: Some electrical equipment such as motors, power converters, etc. may give the appearance of a ground fault, due to normal, non-linear behavior. But usually this leakage is much less than the 50 mA level, especially for devices found in a bedroom.

Also refer to “Inadvertent Grounded Neutral” on page 3 for additional information.

Damaged AFCI

Disconnect the load power and the load neutral wires from the AFCI. If it continues to trip, the AFCI may be damaged and should be replaced.

If it is not obvious whether the problem is in the AFCI or the circuit, replace the AFCI with a new one. If the new AFCI does not trip, it is likely that the old one was damaged.

Arc Fault Trip

⚠ CAUTION

HAZARD OF INJURY OR EQUIPMENT DAMAGE

Do not continue to use any suspect loads until they are inspected and serviced. Replace them if necessary.

Failure to follow this instruction can result in injury or equipment damage.

Tripping due to an arc fault appears to be instantaneous as do those from a short circuit trip and a ground-fault trip (typically in less than one second). The only type of tripping that responds relatively slowly is tripping due to overloads (seconds or tens of seconds). If an arc-fault is suspected, the first diagnostic step should be to determine if the arc fault is in the appliance, its power cord, or if it is in the permanent wiring.

Figure 7: Damaged Electrical Cord

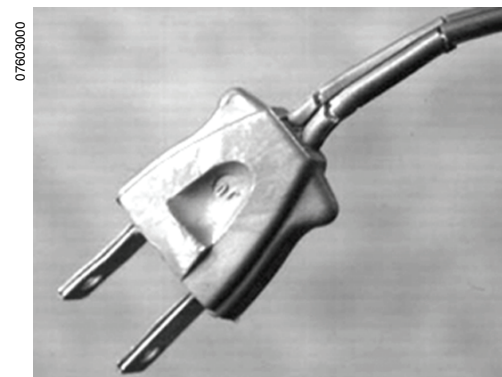

Old, damaged electrical cords are a common place for short circuits.

Checking Appliances

To narrow the problem down to the appliance or its power cord, first, isolate all appliances by unplugging them. If the AFCI does NOT trip when it is reclosed, then the problem is likely an arc fault in either the appliance or its power cord.

A series arc fault will not be detected until a load is connected and energized. The faulty appliance can be identified by connecting one load at a time until the AFCI trips again. Check the last load connected for arcing, insulation problems, shorted or pinched wires, etc.

For additional information refer to “Types of Faults” on page 7. Also see “Example 4—Arc Fault Trip” on page 9.

Checking Permanent Wiring

If the AFCI continues to trip after all of the appliances are unplugged, then a problem in the permanent circuit or a problem with the AFCI can be considered. First, check for arcing, insulation problems, and shorted or pinched wires at outlets, switches, and junction boxes.

For additional information refer to “Types of Faults” on page 7.

Types of Faults

The following table can be used to determine the type of fault that may cause an AFCI to trip.

⚠ CAUTION

HAZARD OF INJURY OR EQUIPMENT DAMAGE

It is important to recognize that the AFCI has provided an indication of a condition that could be a fire hazard. Do not continue to use a circuit in this condition without correction.

Failure to follow this instruction can result in injury or equipment damage.

Table 1: Types of Faults Leading to AFCI Tripping

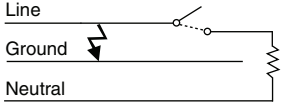
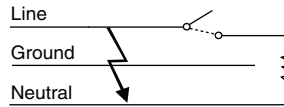
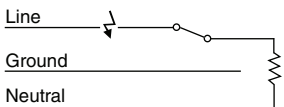
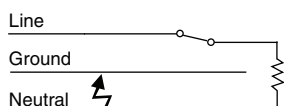
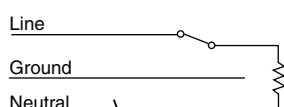
Type of Fault	Current Available at the Fault ¹	Detected by: (AFCI Type)	Description
	50 mA	Branch/Feeder AFCI Combination AFCI	The AFCI trips with or without a load connected to a receptacle.
	75 A	Branch/Feeder AFCI	
	5 A	Combination AFCI	The AFCI trips only with a load connected to a receptacle.
	50 mA	Branch/Feeder AFCI Combination AFCI	
	5 A	Combination AFCI	

¹ Values are approximate.

Examples

Example 1—AFCI Trip Due to Overload

NOTE: When calculating loads, always include everything on the circuit. Keep in mind that the circuit may serve loads outside the affected room.

The bedroom AFCI trips about 30 seconds after a blow-dryer is turned on. The following devices shut off at the same time.

Electric space heater	1,300 watts
Dresser lights	150 watts
Floor lamp	150 watts
Television	200 watts
Coffee maker	600 watts
Hair dryer	1,200 watts
Total	3,600 watts

In example one, the trip was not instantaneous. This indicates an overload trip.

Calculating the total load of the circuit results in a total of 3,600 watts, far exceeding the 2,400 watts that a 20 A AFCI can serve without tripping. In fact, checking the trip curve for the AFCI shows that tripping should occur in 30 seconds when subjected to an overload of 1.5 times the rating (in this case, 3,600 watts).

One of the more obvious fixes for this example would be to leave the space heater off while using the hair dryer. Reset the AFCI and turn on each device except the space heater.

Example 2—Short Circuit in the Device

The bedroom AFCI trips immediately whenever the electric space heater is turned on, causing everything in the room to turn off. Unlike the previous scenario, the hair dryer is not in use and there is no 30-second delay.

In example two, the trip was instantaneous. This indicates some kind of short circuit, or possibly a ground fault or arc fault.

First, determine what load may have been added to the circuit when the circuit breaker tripped. In this case, it was the electric heater, so it should be unplugged and checked for shorts—if the circuit breaker can be reset when the electric heater is disconnected, this would indicate a possible short in the heater or its electrical cord, but may also indicate a ground fault or arc fault.

Example 3—Ground Fault Trip

Neither an overload nor a short circuit are found to be the cause of the bedroom AFCI tripping. Does this mean the trip was caused by an arc fault?

Not necessarily. An AFCI can also be tripped by the presence of a ground fault.

In example three, disconnect all appliances from the circuit. Substitute a GFI circuit breaker for the AFCI. If the GFI trips, then there is probably a ground fault in the circuit. If the GFI does not trip, add the appliances to the circuit. If the GFI trips when one of the appliances is added, that appliance must be replaced or repaired. If the GFI does not trip when all of the appliances are added, there is probably not a ground fault.

Example 4—Arc Fault Trip

The AFCI trips only when someone is sitting in a rocker in the corner.

The old lamp cord passing under the rocker has been there long enough so that the insulation on both conductors has been damaged, causing a parallel arc fault (line to neutral).

The cord should be replaced.

In example four, disconnect all appliances from the circuit. The AFCI does not trip when reclosed, so the problem would appear to be one of the appliances. A series arc fault will not be detected until a load is connected and energized. See further discussion below.

Connecting them one load at a time shows that the AFCI trips when the lamp in the corner is plugged in. An inspection of the lamp shows that the lamp cord, which is old and worn, has damage to the insulation on both conductors, causing a parallel arc fault (line to neutral).

Example 5—Inadvertent Grounded Neutral

The wiring in a new split-level is complete and the electric utility has hooked up the meter. Inspection shows that all the circuits are fine—except for one bedroom AFCI. It trips whenever a ceiling light is turned on.

To determine if the problem in example five is a grounded neutral, visually inspect the wiring at the ceiling light fixture. Discovery of the bare ground wire touching the neutral wiring connector of the lamp shows an inadvertent grounded neutral. The symptom—the AFCI tripping immediately when the lamp is turned on—is explained by the ground wire touching the neutral.

Conclusion

Just as in existing installations, parallel arc faults in new installations are generally an infrequent cause of an AFCI tripping. However, if other causes of tripping have been ruled out, look at two potential arc fault causes:

Series arcing: A series arc is caused by a break in a conductor, and low current flow created by the high-resistance break attempts to cross the break and thus arcs. Loose connections can also be the cause of a series arc. Branch/feeder circuit breakers typically do not detect and clear the lower-energy, series arcs, unless the condition involves a fault to ground. However, the AFCI circuit breaker will detect and clear this type of fault. The sensing circuitry in the AFCI circuit breaker will sense either a parallel or series arc fault as low as 5 amperes and residual current levels starting at approximately 50 mA

Parallel arcing: A parallel arc is caused by an arcing fault between the line conductor and either neutral or ground. While these may be easy to detect in appliances and their electric cords, they can be difficult to locate in the permanent wiring. The most common cause of arcing in permanent circuits is a nail or screw driven through the wall into the conductor, damaging the insulation, and creating a low impedance path for the arc.

Understanding the different trip functions of an AFCI can help to determine why it has tripped. The preceding examples are not comprehensive but they should serve as a beginning guide to help you determine what has happened to cause a trip and what the proper correction should be.

Schneider Electric USA
3700 Sixth St SW
Cedar Rapids, IA, 52404 USA
1-888-SquareD (1-888-778-2733)
www.us.SquareD.com

Electrical equipment should be installed, operated, serviced, and maintained only by qualified personnel. No responsibility is assumed by Schneider Electric for any consequences arising out of the use of this material.

© 1999–2007 Schneider Electric All Rights Reserved

